



Technical Information

Insulation requirements for fabric expansion joints

RAL-GZ 719

TI-011

Rev. 2 – 05/18

page 1 of 3

In general never cover or insulate non-metallic expansion joints at the outside.

In any case contact supplier for final approval if enclosures or outside insulation will be installed.

The thermal influence of adjacent elements has to be respected.

According to the type of expansion joint, following designs are possible:

1. Interface duct insulation

Interface insulation is unconditionally required in case of outside insulated pipes and ducts.

Neither the expansion joint nor the fixation elements must not be insulated in order to provide an unobstructed thermal convection.

According to the type of the expansion joint, different arrangements are required.

a. Principle example for flange-type expansion joint:

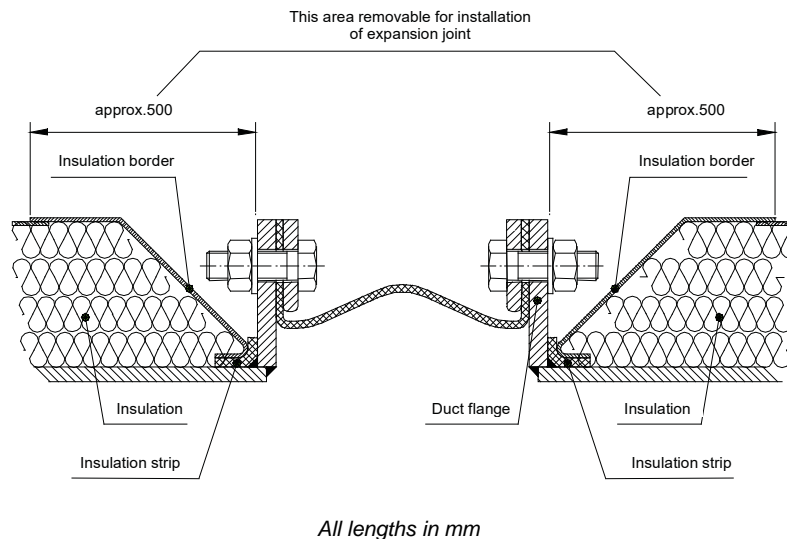

**Edited by the Quality Committee of the Quality Association
for Fabric Expansion Joints**

b. Principal example for belt-type expansion joint:

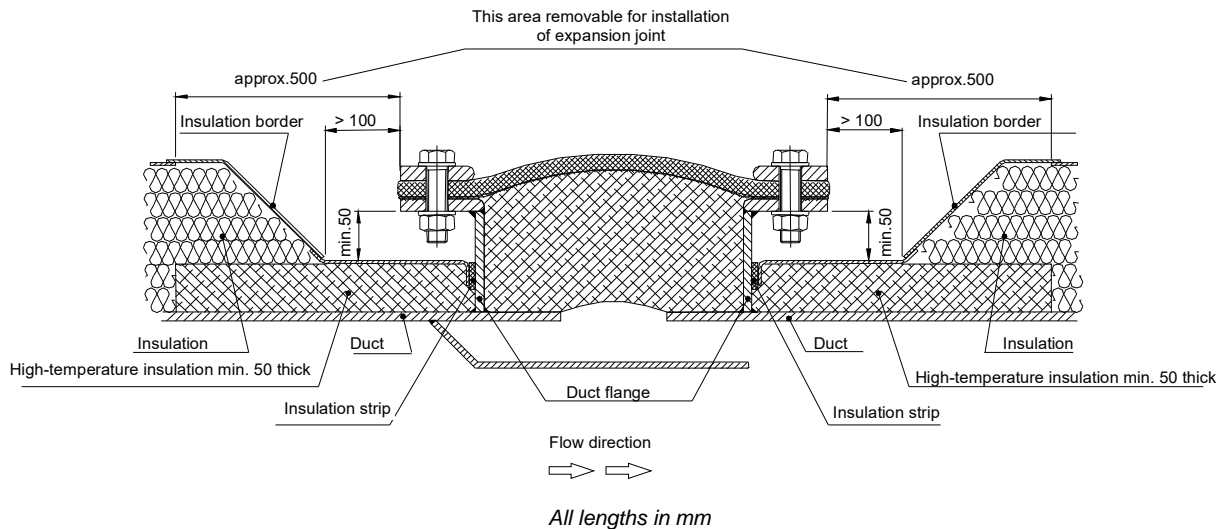

2. Covers

Please note following issues when installing covers for example as acoustic insulation, weather shrouds or covers for shock protection:

- Movements of the expansion joint must not be restricted
- Grant sufficient airflow at entire circumference
- Ensure air circulation with low temperature ambient
- Heat trapping and thermal bridges must be avoided

Deformations of the expansion joint, especially arches being formed during operation, have to be respected.

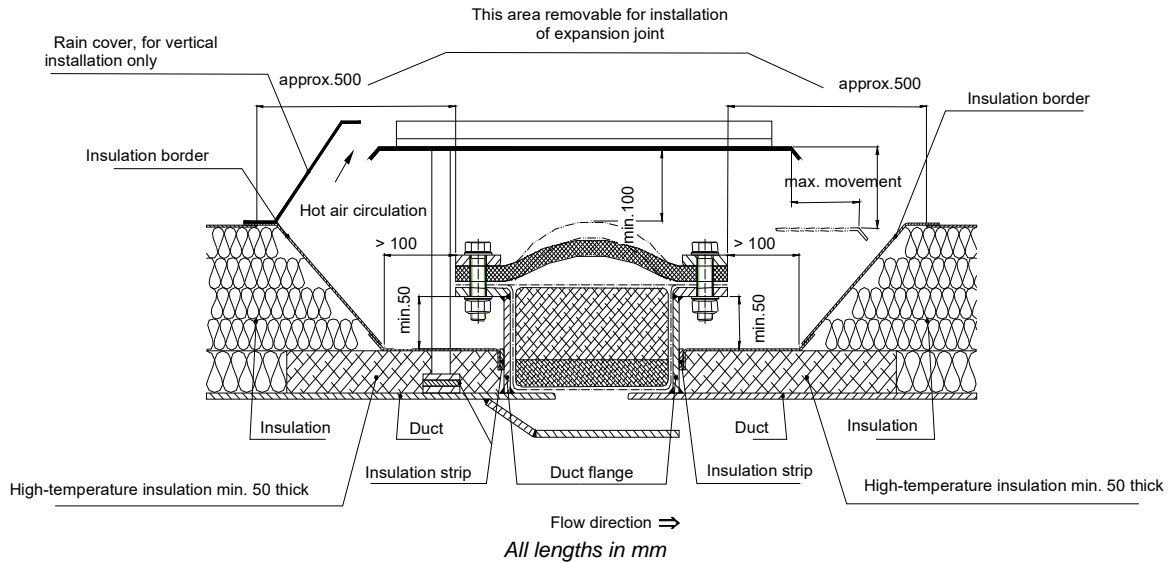

3. External insulation

Contact the supplier in any case if the expansion joint shall be externally insulated.

The maximum operation temperature of externally insulated expansion joints shall not be higher than the maximum allowed operation temperature for the material of the make-up which has the lowest thermal resistance.

External insulation applications for temperatures above 260 °C require a serious technical design.

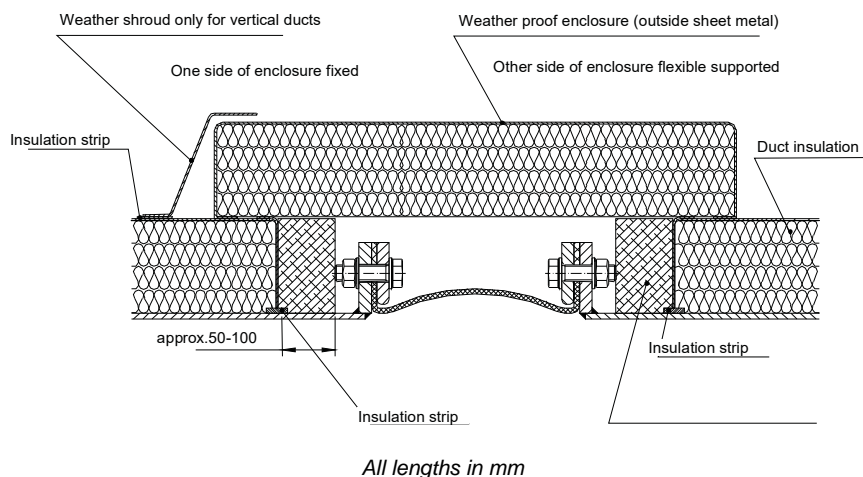

**Edited by the Quality Committee of the Quality Association
for Fabric Expansion Joints**